

J | Ä | S | P | I[®]

HEATING TECHNOLOGY

JASPI-GTV 270, 500, and 700 THERMAL STORAGE TANKS

Classy and efficient, the **GTV** thermal storage tanks are suitable for new applications as well as heating system renovations.

JASPI-GTV 270 is especially suitable for use with dual fuel boilers.

The tank ensures more efficient operation of a solid fuel/pellet boiler and improves the efficiency of the combined oil/gas fuel operation. GTV 270 can be also added to the boiler system as a separate water heater. It can be positioned either vertically or horizontally (e.g. on the ceiling or wall of the boiler room).

JASPI-GTV 500 is used as a heat store for larger energy quantities. Connected in series, GTV 500 thermal tanks are a good solution for more powerful solid fuel heating or night-time electric charge. A hot water coil will be selected for GTV 500 based on hot water supply demand.

JASPI-GTV 700 is designed to be connected to various, simultaneous energy sources. It can be used as a heat store for heat pumps, solid fuel, pellet, oil & gas boilers. Also Solar and wind power systems can be connected. GTV 700's two hot water coils ensure constant high pressure hot water supply.

GTV 700 can accommodate up to 3 separate heat sources. The solar indirect coil can also be added at a later stage.

JASPI-GTV thermal tanks feature thick, high-efficiency polyurethane insulation minimizing the ambient heat loss.

All JASPI-GTV thermal tanks have a powder painted steel casing, are designed to fit through narrow openings and can be positioned in confined spaces.

Indirect hot water coils are flange mounted and can be easily installed later on or replaced if needed. GTV thermal tanks have also up to 3 connections for electric immersion heaters.



JASPI-GTV 270 Thermal Storage Tank

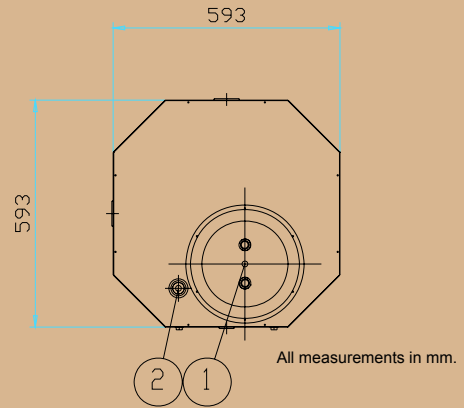
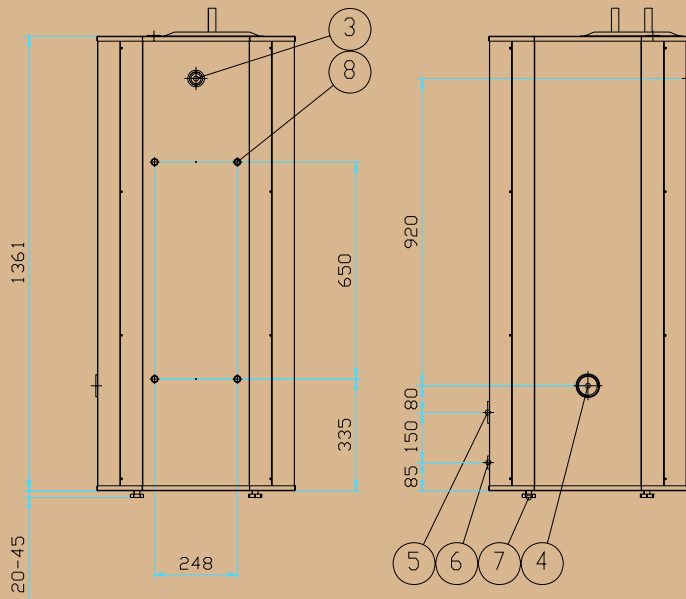

SPECIFICATIONS GTV 270

VERTICAL MOUNTING

1. Ø22 replaceable hot water coil
2. R 1" heating flow / expansion connection
3. R 1" boiler supply
4. R 2" electric immersion heater / boiler return
5. R 2" electric immersion heater / boiler return
6. R 1" heating return
7. M10 adjustable legs
8. M10 horizontal mounting screws

HORIZONTAL MOUNTING (screws on top)

1. Ø22 replaceable hot water coil
2. R 1" heating flow / expansion connection
3. R 1" boiler supply / expansion connection
4. R 2" electric immersion heater
5. R 2" heating return
6. R 1" boiler return
7. M10 adjustable legs
8. M10 horizontal mounting screws

Model	Volume	Weight	Pressure	Hot water coil	
GTV	l	kg	bar	l/min	
270-1.5	270	110	1.5	-	-
270-35-1.5	270	110	1.5	35	Ø22 Cu
270-4	270	110	4	-	-
270-35-4	270	110	4	35	Ø22 Cu

Design temperature: 100°C

We reserve the right to modify design and dimensions

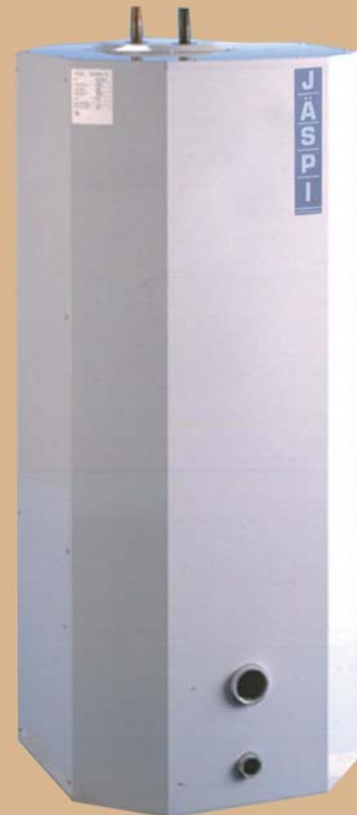
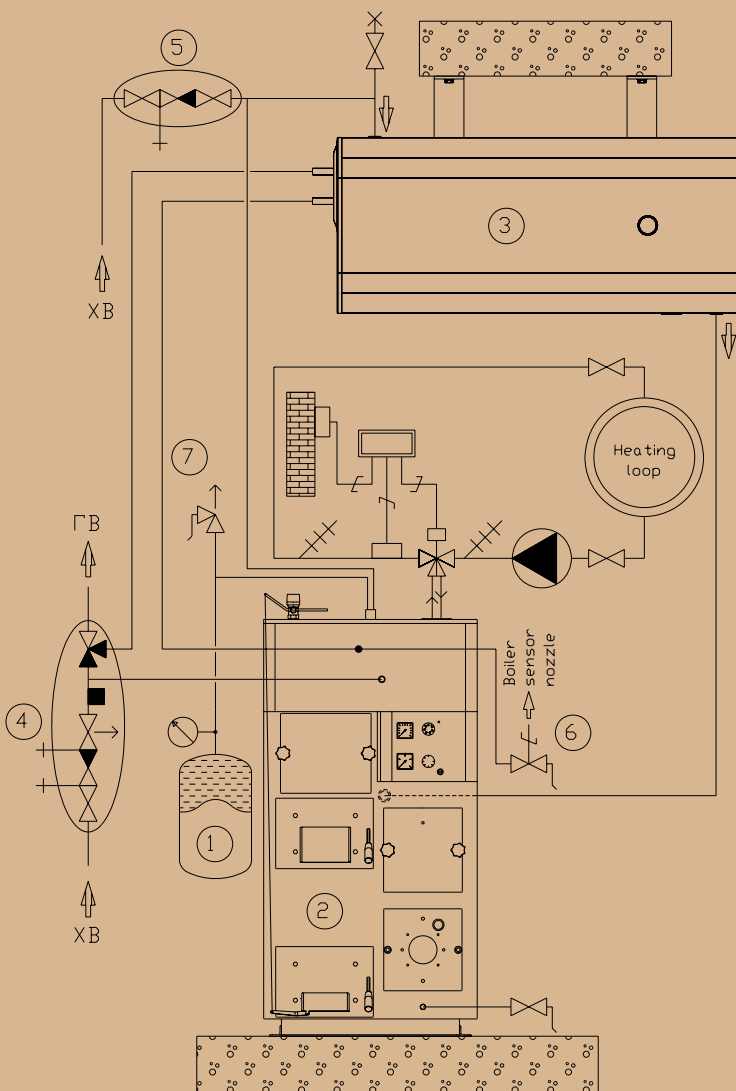

GTV-270 HORIZONTAL CONNECTION TO THE COMBINATION BOILER

1. Expansion vessel
2. Solid wood / Oil combination boiler
3. GTV-270 thermal tank
4. Thermostatic mixing hot water supply valve
5. Boiler water filling valve
6. Thermal safety valve
7. 1.5 bar safety valve

JASPI-GTV 500 Thermal Storage Tank

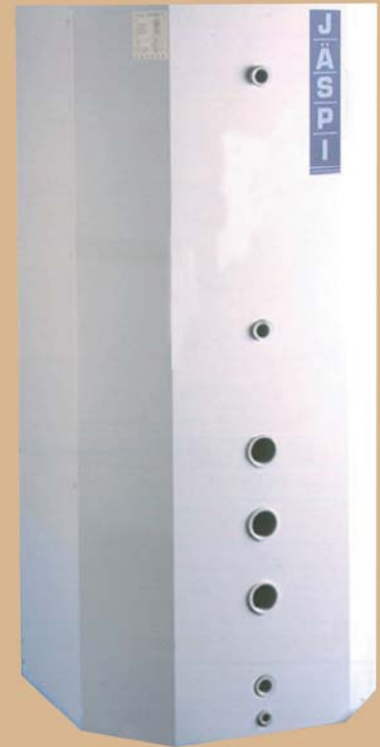
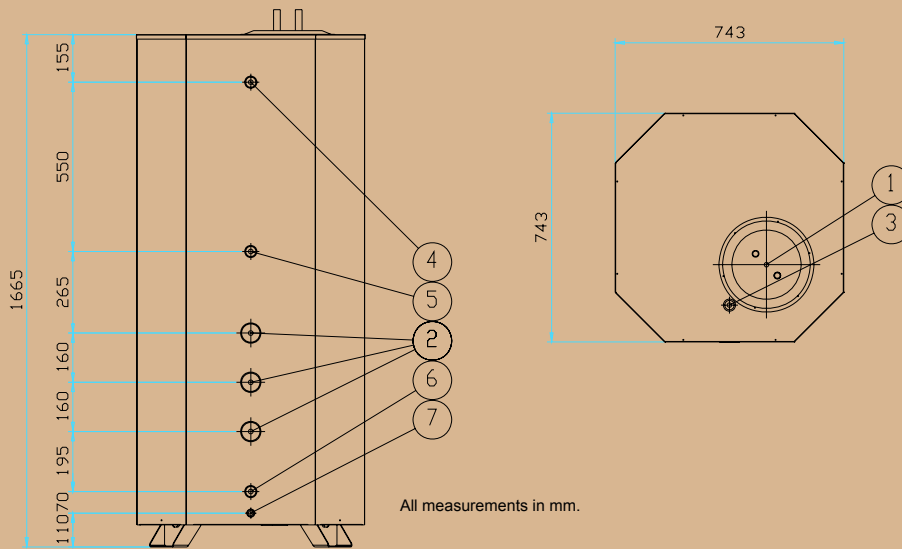

SPECIFICATIONS GTV 500

1. Replaceable hot water coil
2. R 2" electric immersion heater
3. R 1" heating circuit flow
4. R 1" boiler supply
5. Additional R 1" heating circuit flow / return
6. R 1" boiler return / heating circuit return
7. R 1/2" drain

Model	Volume	Weight	Pressure	Hot water coil
GTV	l	kg	bar	l/min
500-1,5	500	180	1,5	-
500-35-1,5	500	180	1,5	35 Ø22 Cu
500-80-1,5	500	180	1,5	80 R25
500-4	500	180	4	-
500-35-4	500	180	4	35 Ø22 Cu
500-80-4	500	180	4	80 R25
500-100-4	500	180	4	100 R32

Design temperature: 100°C

We reserve the right to modify design and dimensions

GTV-500 TO BOILER CONNECTION

1. Heat source, solid wood boiler, heat pump etc.
2. GTV-500 thermal storage tank
3. Thermostatic mixing hot water supply valve
4. Heating circuit circulating pump
5. Charging pump
6. Expansion vessel
7. Required quantity of electric immersion heaters
8. Boiler filling valve
9. Thermal safety valve
10. 1.5 bar safety valve
11. Thermostatic charging valve
12. Pump thermostat

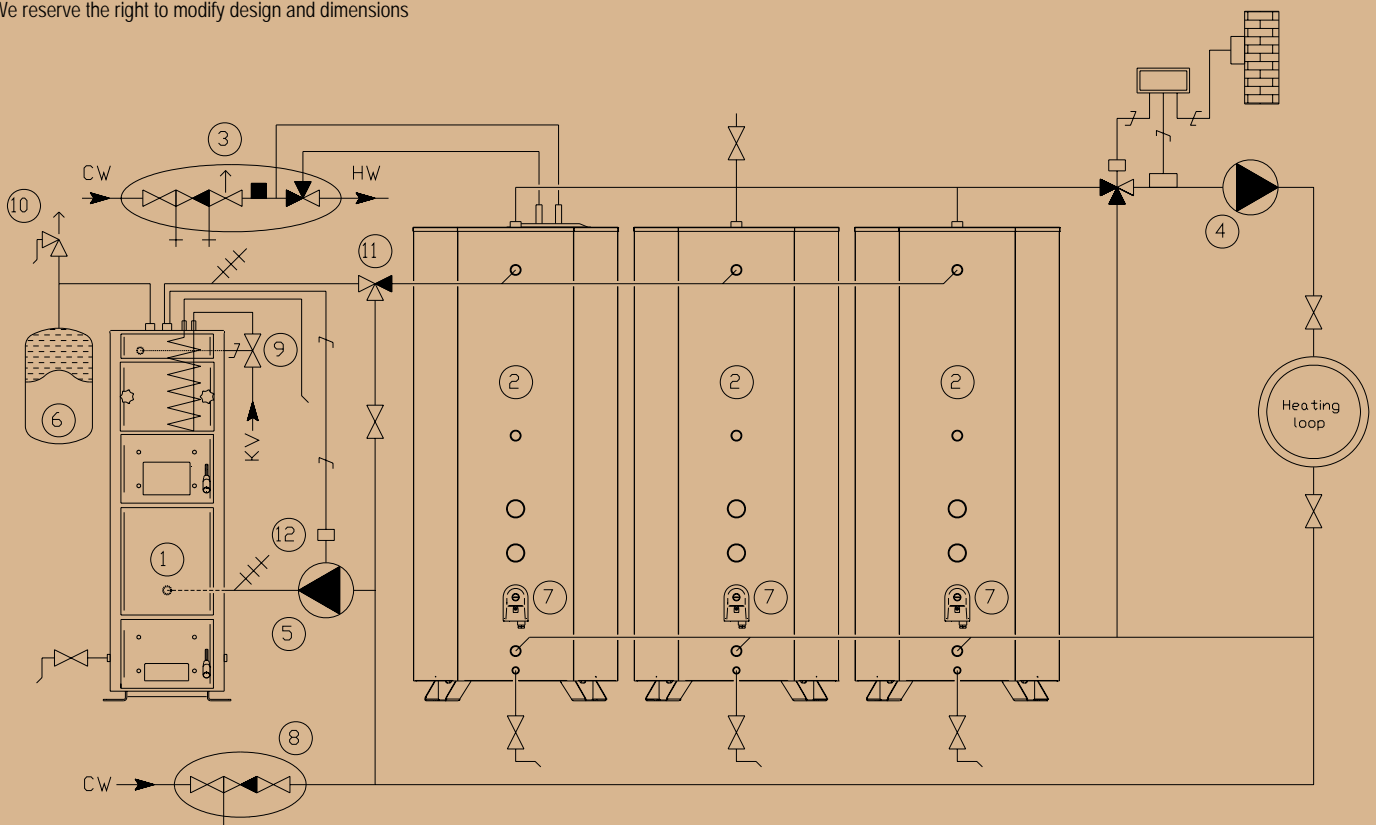

JASPI-GTV 700 Thermal Storage Tank

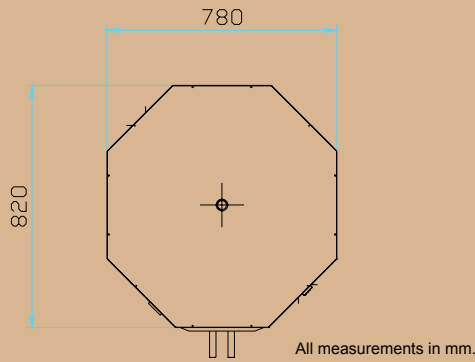
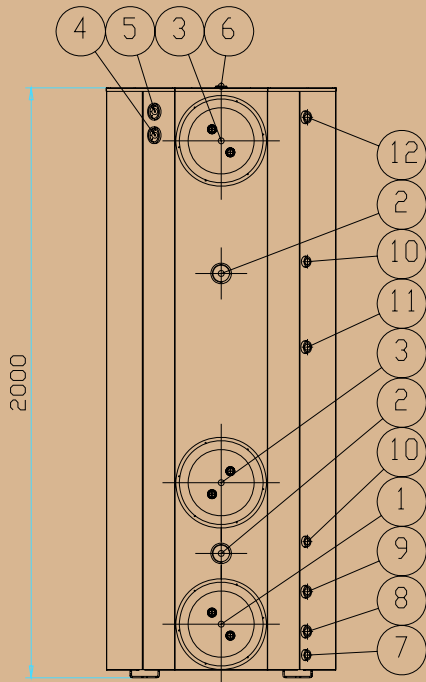

SPECIFICATIONS

1. Ø22 Cu solar power coil (optional)
2. R 2" BP electric immersion heater
3. Ø22 hot water and additional heat source coils
4. R 1/2" lower level thermometer
5. R 1/2" upper level thermometer
6. R 1" BP heating circuit outlet/expansion (ensure deaeration)
7. R 3/4" BP drain
8. R 1" BP heating circuit return (expansion)
9. R 1" BP underfloor heating circuit return
10. R 3/4" BP thermostat
11. R 1" BP underfloor heating supply. Can also be used as an additional heating circuit feed
12. R 1" BP direct boiler connection



Model	Volume	Weight	Pressure	Hot water coil	
GTV	l	kg	bar	l/min	
700 IK	700	250	1,5	-	-
700	700	250	1,5	35	Ø22 Cu

Design temperature: 100°C

We reserve the right to modify design and dimensions.

J | Ä | S | P | I®

HEATING TECHNOLOGY

KAUKORA OY

NORTHMAN

NORTHMAN JASPI UK

www.jaspi.co.uk Telephone 01392 247 340